



Model 657
Ratchet Lever Hoist
3/4 - 6 Ton Capacity

The Industry Leader In Lever Hoists

CM Hoists 657 Models are available with optional Load Limiters. Also featuring through-hardened load chain, these stamped steel ratchet lever hoists are lightweight, durable and are ideal for construction and commercial applications. All 657 hoists are metric rated.

- **CAPACITIES & LIFT** - Rated loads of 3/4, 1 1/2, 3 and 6 tons, with 5, 10, 15 and 20 foot standard lifts. Other lifts available.
- **OPTIONAL LOAD LIMITER** - Load Limiter alerts operator of a possible overload by allowing the handle to rotate without lifting the higher-than capacity load. The load limiter can be field-installed.
- **RUGGED AND LIGHTWEIGHT** - Impact resistant, stamped steel housing withstands rigorous use. Compact design is portable and easy to rig.
- **LOW HANDLE EFFORT** - Double reduction gearing and short, cushioned-grip handle provide easy operation with minimal handle effort.
- **360° ROTATING HANDLE** - Provides versatile rigging options when used in confined spaces.
- **EASY FREE CHAINING** - State-of-the-art free wheeling mechanism allows quick and easy one-handed take-up and positioning of slack chain.
- **POSITIVE LOAD CONTROL** - Enclosed screw-and-disc type load brake stays clean and dry for positive load positioning. Latches on hooks provide positive load engagement.
- **OPTIONS** - Shipyard hook available for 1 1/2 ton & 3 ton models
- **LIFETIME WARRANTY**

SPECIFICATIONS

3/4 - 6 Ton

Capacity		Product Code	Lift (Ft.)	Strands of Load Chain	Minimum Dist. Between Hooks (In.)	Handle Length (In.)	Average Handle Effort (lb.)	Net Weight (Lbs.)
(lb.)	(Ton)							
1500	3/4	5720	5	1	11 5/8	9 1/4	46	12
1500	3/4	5721	10	1	11 5/8	9 1/4	46	14
1500	3/4	5722	15	1	11 5/8	9 1/4	46	16
1500	3/4	5723	20	1	11 5/8	9 1/4	46	18
2000	1	5736	5	1	12 13/32	9 1/4	57	12
2000	1	5737	10	1	12 13/32	9 1/4	57	14
2000	1	5738	15	1	12 13/32	9 1/4	57	16
2000	1	5739	20	1	12 13/32	9 1/4	57	18
3000	1 1/2	5724	5	1	13	14 9/16	59	21
3000	1 1/2	5725	10	1	13	14 9/16	59	24
3000	1 1/2	5726	15	1	13	14 9/16	59	27
3000	1 1/2	5727	20	1	13	14 9/16	59	30
6000	3	5728	5	1	16 15/16	14 9/16	75	35
6000	3	5729	10	1	16 15/16	14 9/16	75	40
6000	3	5730	15	1	16 15/16	14 9/16	75	45
6000	3	5731	20	1	16 15/16	14 9/16	75	50
12000	6	5732	5	2	22 3/4	14 9/16	76	67
12000	6	5733	10	2	22 3/4	14 9/16	76	77
12000	6	5734	15	2	22 3/4	14 9/16	76	88
12000	6	5735	20	2	22 3/4	14 9/16	76	99

* Standard lifts shown. Other lifts available - Consult factory

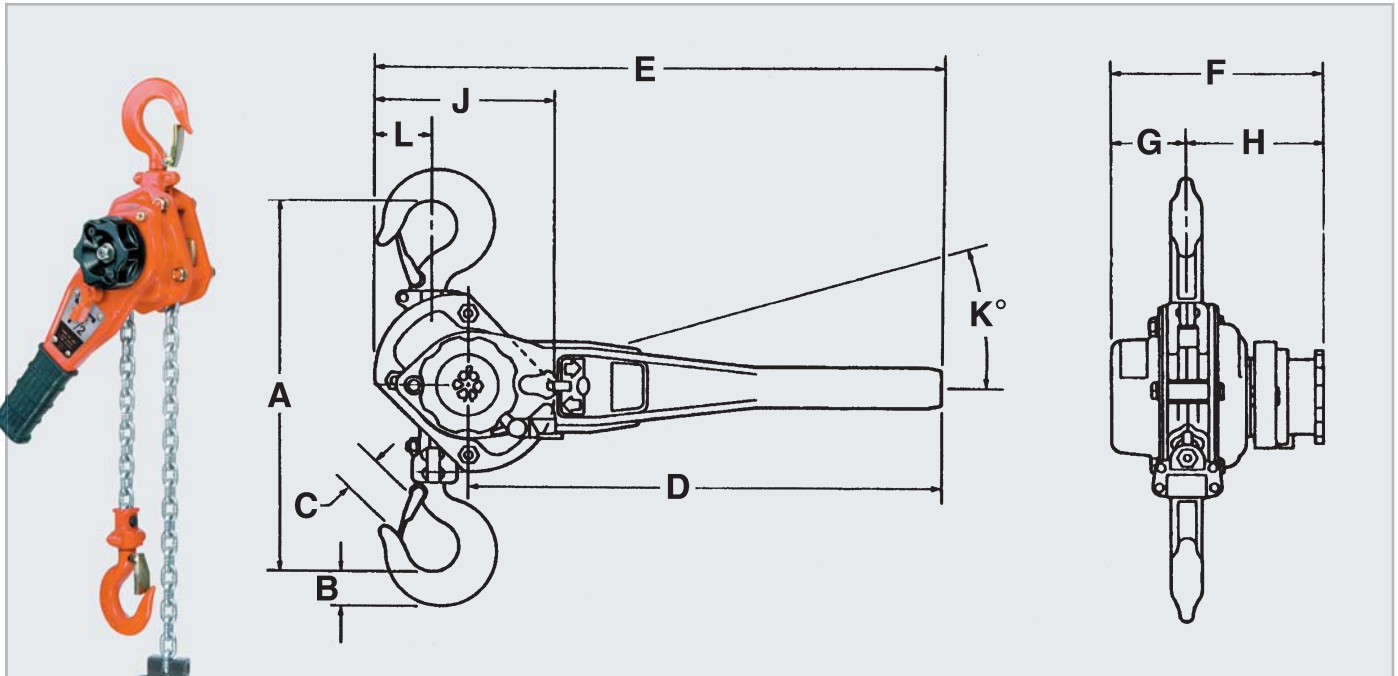

DIMENSIONS

All dimensions are in inches unless otherwise indicated

Capacity		A	B	C	D	E	F	G	H	J	K	L	Number of Load Chains
(lb.)	(Ton)												
1500	3/4	11 5/8	13/16	15/16	9 1/4	11 7/16	5.59	2.06	3.54	4.72	9°	1.50	1
2000	1	12 13/32	1	15/16	9 1/4	11 7/16	5.59	2.06	3.54	4.72	9°	1.5	1
3000	1 1/2	13	1 1/16	1 1/4	14 9/16	17	6.42	2.54	3	5.45	9°	1.62	1
6000	3	16 15/16	1 3/8	1 7/32	14 9/16	18 3/16	7.28	3.22	4.03	7.00	9°	2.10	1
12000	6	22 3/4	2 1/16	1 3/4	14 9/16	20 5/16	7.28	3.22	4.03	10.20	9°	3.34	2

⚠ WARNING

Overloading and Improper Use Can Result In Injury

To Avoid Injury:

- Do not exceed working load limit, load rating, or capacity.
- Do not use to lift people or loads over people.
- Use only alloy chain and attachments for overhead lifting.
- Read and follow all instructions.

Shipyards Hooks Now Available

Shipyards Hooks -- used on select, steel body, lever-operated hoists -- were designed to effectively position steel plate and fixtures before welding. This application is ideally suited to the ship building and metals fabrication industries. Available in 1 1/2 and 3 ton working load limit sizes, the upper hook model quickly replaces the standard hook and features a special trunnion which attaches directly to the hoist body. The lower hook is equipped with a chain block for direct attachment to the load chain of the hoist.



140 John James Audubon Parkway
 Amherst, NY 14228 USA
 (800) 888-0985 / (716) 689-5400
 FAX (716) 689-5644
 www.cmindustrial.com



Upper Hook

Lower Hook

Capacity (Ton)	Product Code	Net Weight (lb.)
UPPER		
1 1/2	3315WLP	2.9
3	3303WLP	4.9
LOWER		
1 1/2	3415WLP	2.1
3	3403WLP	4.8

