

Series 602/603 mini ratchet lever hoist

McLaughlin Hoist & Crane
Authorized Sales & Service

(636) 343-9700

www.stlcrane.com

Mini-Ratchet Lever Hoists lift up to 1100 lbs. plus the convenience of toolbox storage.

The CM Series 603 & 602 Mini- Hoists are the most compact ratchet lever hoists in the market, perform just like the larger models, plus come standard with these great features:

- Plated load chain is standard.
- Weston-type load brake.
- Rubber hand grip for better comfort and security.
- Lightweight design for ease of portability. Use in confined conditions with one-hand operation.
- Forged upper and lower hooks with latches standard.
- Impact resistant, all-steel frame, gear case and cover.
- Hardened link-type alloy steel load chain for strength and long wear.
- Free wheeling feature serves to quickly attach the load.
- Metric rated.



603
1100 Lb.
Capacity

602
550 Lb.
Capacity

**5 Ft. &
10 Ft. Lifts**



Our compact Mini-Hoists perform just like the larger hoists, except they're small enough to fit in the palm of your hand.



Convenient Carry Bag -
Product Code # 0212

SPECIFICATIONS

Product Code	Model Number	Rated Capacity (Lbs.)	Rated Capacity (Kg.)	Standard Lift	Number of Chainfalls	Minimum Distance Between Hooks (In.)	Lift w/ One Full Lever Turn (In.)	Handle Length (In.)	Handle Pull @ W.L.L. (Lbs.)	Approx. shipping wgt. (lbs)
0210	Series 602	550	250	5	1	9.45	3.15	6.300	56	6
0214	Series 602 w/10' lift	550	250	10	1					7
0212	Series 602 Carry Bag									.3
0215	Series 603	1,100	500	5	1	11.125	1.57	6.375	78	7
0216	Series 603 w/10' lift	1,100	500	10	1	11.125	1.57	6.375	78	8
0217	Series 603 Carry bag									.3

Series 602 mini ratchet lever hoist-Specifications

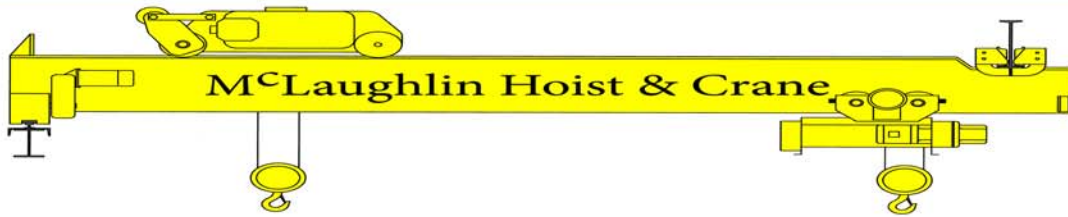

Dimensional Drawing - 602

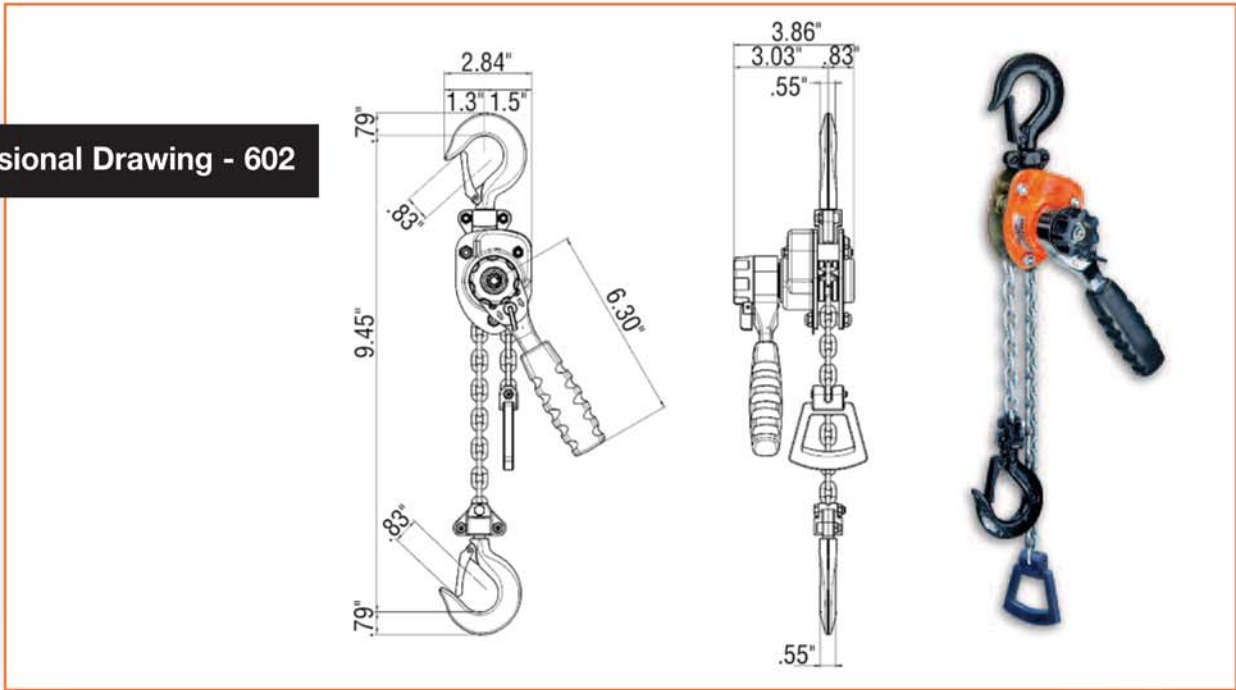

Dimensional Drawing - 603

