

AZ-80/99

SECTION AT/Z

**CHESTER
HOIST**

Service Instructions and Parts List
Zephyr **ARMY TYPE TROLLEY HOISTS**
 Keep for Future Reference

IMPORTANT**CAUTION:**

THE EQUIPMENT ILLUSTRATED AND DESCRIBED IN THIS BULLETIN IS DESIGNED FOR MANUAL OPERATION ONLY AND IS NOT TO BE POWER DRIVEN, NOR IS IT SUITABLE FOR LIFTING PEOPLE.

This unit is a standard Zephyr spur geared hoist suspended on a special load bar, carried at each end by a precision bearing equipped two-wheel trolley. One-quarter through 2 Ton capacity.

These trolley hoist units are adjustable to varying beam sizes and are interchangeable. If your present Army Trolley type hoist is equipped with plain trolleys, a geared unit may be substituted in place of one of the plain trolleys at any time.

**1/4 to 2 TON****3 to 10 TON**

The Zephyr Army type trolley hoist — 3 through 10 Ton capacity — has all the features of the standard Zephyr spur geared hoist except that a Chester Precision Bearing I-Beam Trolley is incorporated in place of the standard load bar and two-wheel trolley arrangement. The precision trolley is *fixed* to the hoist and does not swivel as in the case of the 1/4 through 2 Ton units. Although the trolleys are fixed, they are still fully capable of negotiating relatively short curve radii (See Bulletin B). These units are available in both the plain and geared type trolley.

NOTE: All Army Trolley Hoists fabricated in accordance with ANSI B 30.16 and HMI 200.

When ordering parts always specify your hoist serial number.

INSTALLATION ON BEAM

The distance between the trolley wheel flanges (measured at the tread diameter) should be 1/8" to 3/16" greater than the beam flange width for proper running clearance. This clearance should be checked before operating the hoist under load.

Move adjusting spacers to inside or outside of plates as required. The hoist should be traversed the entire length of the beam to check for interference points, proper side clearances and the effectiveness of beam stops.

TROLLEY LUBRICATION

Wheel bearings are lubricated through ball check hydraulic fittings on the hub of each trolley wheel. On geared trolley units, a similar fitting is also furnished on the trolley block. See Part No. C-906-A. Three through 10 Ton: Duo-Sealed Timken Tapered Roller Bearings. One-quarter through 2 Ton: Sealed Precision

Ball Bearings — no lubrication required.

Lubricate frequently and at regular intervals with NLGI Grade 2, complex lithium based grease with E.P. additive.

ZEPHYR ARMY TYPE HOIST PARTS

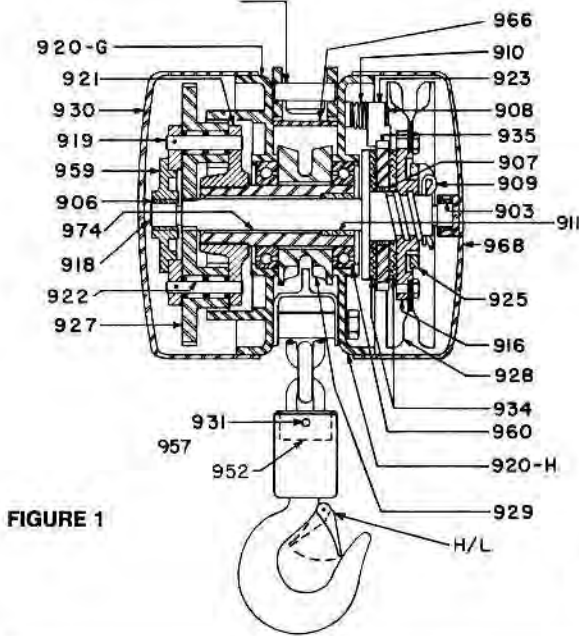
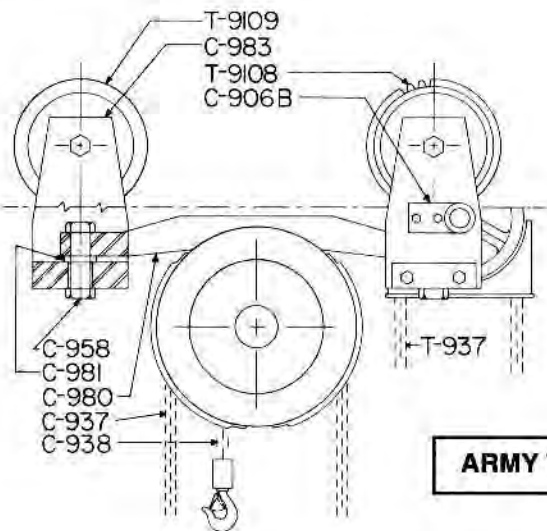
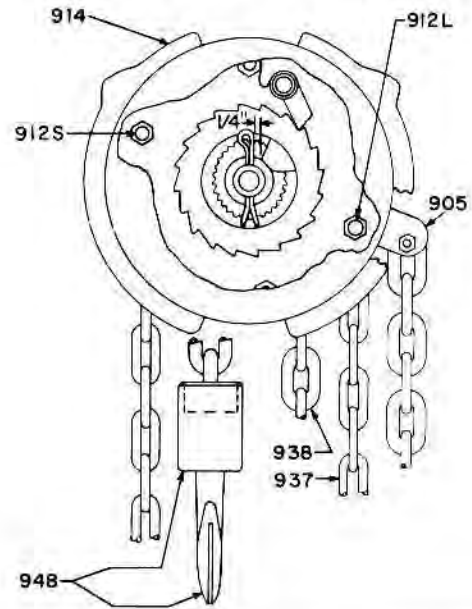

FIGURE 1

1/4 to 10 TON



1/4 to 2 TON

ARMY TROLLEY PARTS NUMBERS

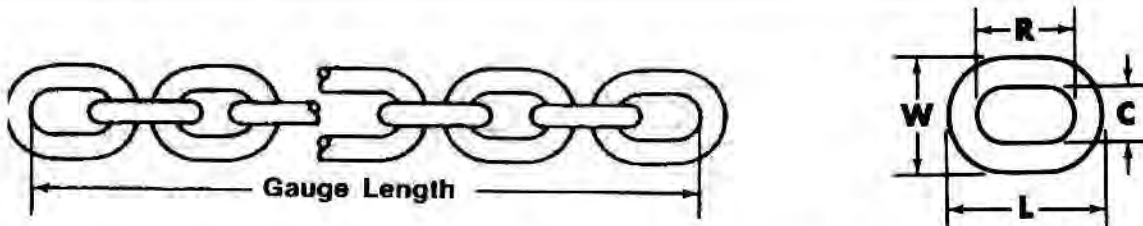
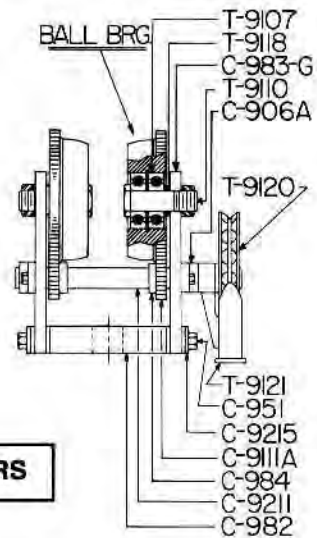

Use and Description	Chain Size	C	W	R	L	Gauge Length	Net Weight
HAND CHAIN							
All Capacities	1/4"	.347	.878	1.048	1.056"	19 links: 20.064"	.43 lbs., ft.
LOAD CHAINS							
1/4 - 1/2 ton	9/32"	.313	.876	.797"	1.357	25 links: 19.925"	.73 lbs., ft.
1 ton (Alloy)	9/32"	.313	.876	.797"	1.357	25 links: 19.925"	.73 lbs., ft.
1 1/2, 2, 3, 4, 5, 6, 8, 10 thru 25 ton.	3/8"	.466	1.206	1.155"	1.897	13 links: 15.015"	1.28 lbs., ft.

HOIST PARTS

QUANTITIES PER CAPACITY IN TONS

Reference No.	Description	1/4 & 1/2	1	1 1/2	2	3	4	5 & 6	8	10
903	Bronze Bushing in Handwheel Cover	1	1	1	1	1	1	1	1	1
905	Load Chain Guide/Stripper	1	1	1	1	1	1	1	1	1
906	Bronze Bushing for 959	1	1	1	1	1	1	1	1	1
907	Bushing 935	1	1	1	1	1	1	1	1	1
908	Pawl Snap Ring	1	1	1	1	1	1	1	1	1
909	Cotter Pin 135-.31-2.00	1	1	1	1	1	1	1	1	1
910	Pawl Spring	1	1	1	1	1	1	1	1	1
911	Bronze Bushing for 974	-	-	1	1	1	1	1	1	1
912L	Large Separator Stud	-	-	1	1	1	1	1	1	1
912S	Small Separator Stud	-	-	3	3	3	3	3	3	3
914	Hand Chain Guide	2	2	2	2	2	2	2	2	2
916	Handwheel Threaded Insert	1	1	1	1	1	1	1	1	1
918	Spindle	1	1	1	1	1	1	1	1	1
919	Gear & Pinion Shaft	1	2	2	2	2	2	2	2	2
C920G	Internal Gear Frame	1	1	1	1	1	1	1	1	1
C920H	Handwheel Side Frame	1	1	1	1	1	1	1	1	1
921	Pinion Cage	1	1	1	1	1	1	1	1	1
922	Needle Bearings for Gear & Pinion	2	4	4	4	4	4	4	4	4
923A	Pawl	1	1	1	1	1	1	1	1	1
925	Adjustable Check Washer	1	1	1	1	1	1	1	1	1
927	Gear & Pinion	1	2	2	2	2	2	2	2	2
928	Handwheel	1	1	1	1	1	1	1	1	1
929	Load Sheave	1	1	1	1	1	1	1	1	1
930	Gear Cover	1	1	1	1	1	1	1	1	1
931	Drive Pin	1	1	1	1	-	-	1	-	1
934	Brake Disc, Per/Pair	1	1	1	1	1	1	1	1	1
935	Ratchet with 907 Bushing	1	1	1	1	1	1	1	1	1
937	Hand Chain	1	1	1	1	1	1	1	1	1
938	Load Chain	1	1	1	1	1	1	1	1	1
939	Thrust Bearing	-	-	-	-	1	1	1	1	1
940	Bottom Hook	-	-	-	-	1	1	1	1	1
H/L	Hook Latch	1	1	1	1	1	1	1	1	1
945	Idler Sheave Bearing B2620	-	-	-	-	1	1	2	3	4
C948	Bottom Hook Assembly	1	1	1	1	-	-	-	-	-
	Thru Bolt & Nut	4	4	4	4	-	-	-	-	-
952	Bottom Block, Crosshead or Plug	1	1	1	1	1	1	1	1	1
956	Top or Bottom Idler Sheave	-	-	-	-	1	1	2	3	4
957	Top Yoke or Load Bar Pin	1	1	1	1	1	1	1	1	1
958	Swivel Bolt	2	2	2	2	-	-	-	-	-
959	Pinion Cage Bearing Block	1	1	1	1	1	1	1	1	1
960	Load Sheave Shaft Bearing	2	2	2	2	2	2	2	2	2
966	Load Sheave Shield	1	1	-	-	1	1	1	1	1
968	Handwheel Cover with 903 Bushing	1	1	1	1	1	1	1	1	1
974	Load Shaft, Splined	1	1	1	1	1	1	1	1	1
975	Snap Ring for 985 Sheave Axle	-	-	-	-	2	2	4	6	8
980	Load Bar	1	1	1	1	-	-	-	-	-
981	Flanged Bushing	2	2	2	2	-	-	-	-	-
982	Cross Piece	2	2	2	2	-	-	-	-	-
983	Plain Trolley Side Plate, Geared Unit Qty. - ()	4 (2)	4 (2)	4 (2)	4 (2)	(1)	(1)	(1)	(1)	(1)
983G	Geared Trolley Side Plate	2	2	2	2	1	1	1	1	1
984	Locking Collar	2	2	2	2	-	-	-	-	-
985	Top or Bottom Sheave Axle	-	-	-	-	1	1	2	3	4
906A	Handwheel Shaft Support (Long)	1	1	1	1	-	-	-	-	-
906B	Handwheel Shaft Support (Short)	1	1	1	1	-	-	-	-	-
9103	Equalizing Pin(s)	-	-	-	-	1	1	2	1	2
9104	Adjusting Washer	-	-	-	-	22	27	32	24	52
9106	Handwheel Shaft Support (Long)	-	-	-	-	1	1	1	1	1
9107	Ball Bearing	8	8	8	8	-	-	-	-	-
9108	Geared Trolley Wheel	2	2	2	2	2	2	2	2	2
9109	Plain Trolley Wheel, Geared Unit Qty. - ()	4 (2)	4 (2)	4 (2)	4 (2)	4 (2)	4 (2)	4 (2)	4 (2)	4 (2)
9110	Axel	4	4	4	4	4	4	4	4	4
9111	Pinion Gear & Shaft	-	-	-	-	1	1	1	1	1
9111A	Pinion Gear Only	2	2	2	2	-	-	-	-	-
9112	Adjustable Bearing Nut	-	-	-	-	4	4	4	4	4
9116	Timken Bearing Cone	-	-	-	-	8	8	8	8	8
9117	Timken Bearing Cup	-	-	-	-	8	8	8	8	8
9118	Bearing Spacer C23855 C23854	20	20	12	12	4	4	4	4	4
9120	Trolley Handwheel	1	1	1	1	1	1	1	1	1
9121	Trolley Handwheel Swinging Guard	1	1	1	1	1	1	1	1	1
9211	Pinion Shaft	1	1	1	1	-	-	-	-	-
9215	Side Plate Spacers	28	28	38	38	-	-	-	-	-
9942	Top Connecting Yoke	-	-	-	-	1	1	1	1	1
SPECIAL FASTENERS (NOT SHOWN)										
999	Gear (930) & Handwheel (968) Cover Screw	8	8	8	8	8	8	8	8	8
44-.25-.50 with Washer 3-.25		8	8	8	8	8	8	8	8	8

PART PRICES ON REQUEST - CONTACT FACTORY.

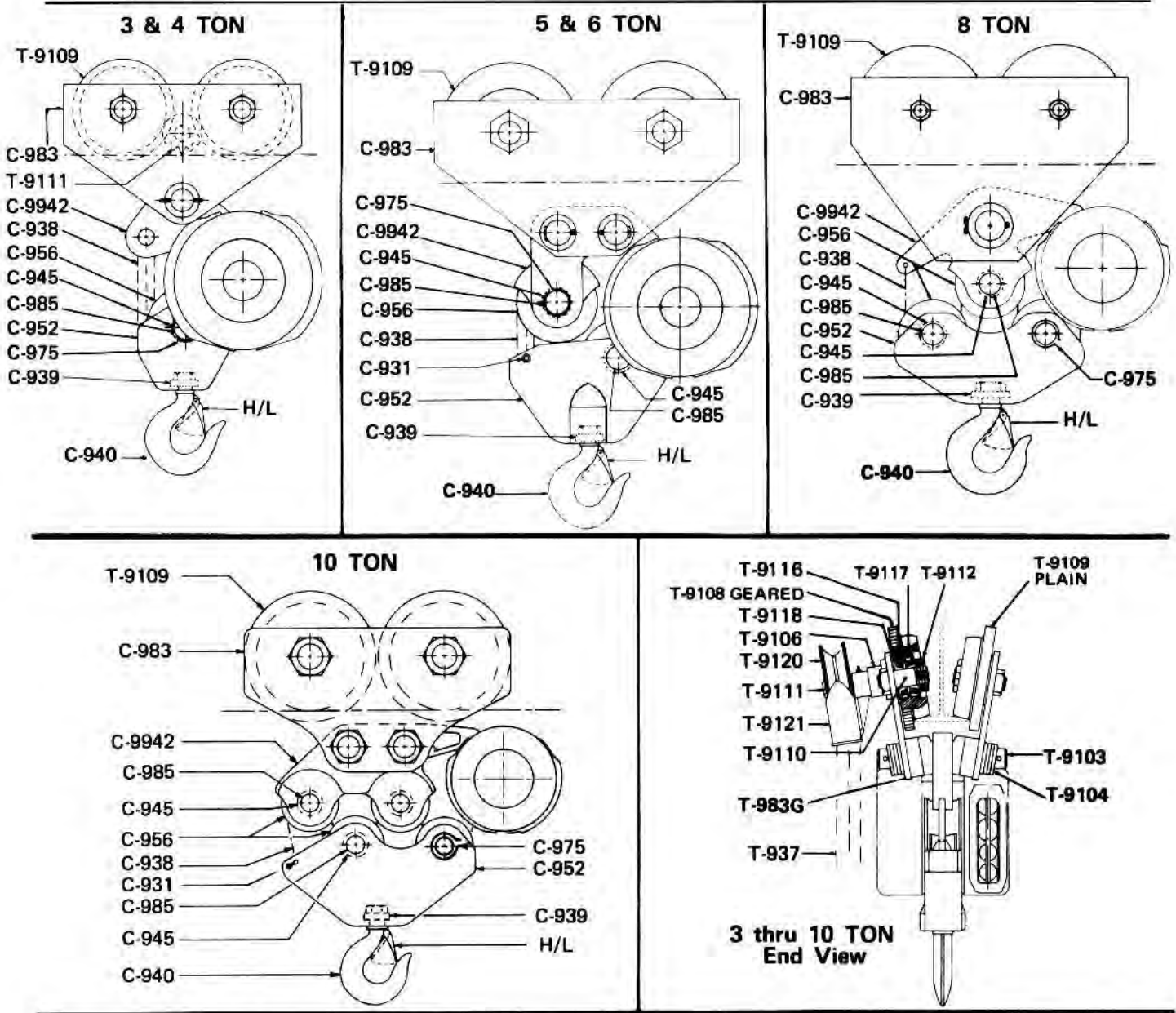

INSPECTING THE HOIST

Following procedure is recommended for a thorough inspection of the hoist. Parts can be identified by referring to Fig. 1, page 2.

1. Inspect bottom hook. Determine if hook may have been stretched. Check bolt attaching bottom yoke to chain, tighten securely.
2. Inspect load chain for wear. Check all inter-link points. Measure gauge length of chain at several points, and compare with dimensions shown in chain chart on Page 2. Increased length will indicate that the chain has been overloaded and stretched, or that excessive wear is taking place.
3. Inspect pockets of load sheave for evidence of wear. Check engagement with load chain for proper action.

4. Try out the brake, and check if it is holding load at all positions, by operating the hoist with and without load.
5. Remove handwheel cover and handwheel, and check the action of the load brake pawl. Determine that it engages properly with the ratchet. Inspect pawl spring and ratchet for wear. Check the distance between pin No. 909 and check washer No. 925, against the minimum required distance of 1/4 inch.
6. Remove spindle and examine pinion teeth, brake washers No. 934, and ratchet for excessive wear.
7. Remove gear cover and inspect all gearing. Check for broken teeth and for excessive wear in the internal gear No. 920-G and the combination gear and pinion No. 927.