

**Yale® Cable King
Air Wire Rope Hoists**

3340B

Yale®



**McLaughlin Hoist & Crane
Authorized Sales & Service**

(636) 343-9700

www.sflcrane.com

Yale Cable King Air Wire Rope Hoists . . . better suited for many applications

Features

- Capacities ½ to 35 tons
- Standard or close head-room models
- Four suspension options: lug, plain trolley, geared trolley, motorized trolley
- Cord or lever pendant control
- Two brakes
- Two limit switches
- Spark resistant models available
- Full range of air hoist accessories

Why an air hoist?

Yale Cable King air wire rope hoists are ideal for many applications and conditions that make electric hoists uneconomical or impractical to operate.

Air motors are sealed against dust, moisture, and corrosive gases. External air is kept out by internal air pressure. This is why air hoists are suited to many grain, coal, and chemical operations.

Air hoists perform well where heat may be a problem—either from extremely heavy duty cycles or from above average ambient temperatures. Since air motors won't

overheat, air hoists are often found in electroplating operations and foundries.

Air hoists are used extensively in chemical and petrochemical industries because there is no danger of electrical sparking with air motors. Spark resistant options easily adapt the Yale Cable King air hoist for use in many flammable environments (see back page).

Precise, almost infinitely variable speed control is a standard feature of the Yale Cable King air wire rope hoist. Expensive electrical controls are not necessary to get precision load spotting capabilities.

We designed the Yale Cable King hoist for long life and minimum maintenance. Lifetime lubricated, precision ball bearings are used extensively to minimize friction. Gears and pinions are heat treated for strength and durability. The entire gear train and load brake are splash lubricated in a continuous oil bath. The load brake is self adjusting. The automotive type drive shaft features lifetime lubricated universal joints. This unique design reduces radial stress on the motor and gear box, thereby maximizing bearing life.

Safety is designed into the Yale Cable King air hoist. Frames are fabricated from heavy structural steel sections and plates. Two brakes are designed to operate independently and each is capable of holding the full rated load. The two limit switches are designed to prevent accidental over-travel of the hook. The bottom block design minimizes the entry of foreign objects. Flexible improved or extra improved plow steel wire rope with hemp or steel center has a minimum safety factor of 5 to 1. Hook latches are standard and the drop forged, heat treated steel load hook is fracture resistant.

Brakes

Load brake



The load brake on Yale Cable King hoists is a self-actuating, Weston screw-and-disc type brake. It is mounted in the gearbox between the first and second gear reductions, and operated in a continuous oil bath to help dissipate heat. The brake is self adjusting and operates whether the power is on or off. The load brake is capable of safely holding the rated capacity of the hoist.

Motor brake



The disc type motor brake controls hook drift and facilitates load spotting. This spring-engaged brake is designed to operate if the air supply is interrupted for any reason. The motor brake is self-adjusting and incorporates cooling fins to dissipate heat. It is enclosed against dirt, water, and oil and is designed to independently hold the full rated capacity of the hoist.

Controls



Yale Cable King hoists are equipped with either a modular pendant control (standard) or pull cord (optional). The cast aluminum pendant controls incorporate levers for single motor operations. Pendants can be supplied to operate up to three air motors using buttons in addition to the levers. This results in an extremely compact and lightweight control unit.



The air pressure in the pendant control is variable from 20 to 80 psi and actuates a pilot control valve on the hoist motor. Since full line pressure does not pass through the pendant hoses, longer lifts are possible without dramatic loss of hoisting speed.

Pendant hoses are $\frac{1}{4}$ inch inside diameter with NPT end connections, and are fastened together to prevent snagging. Pendants are supported by a strain cable.

Limit switches

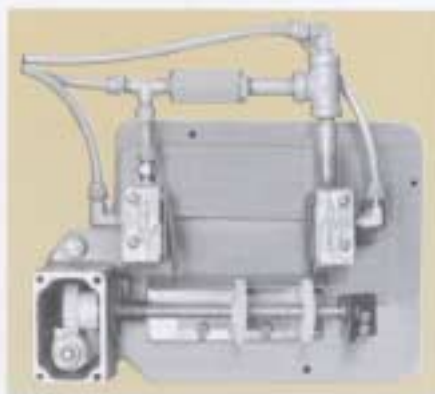

A geared traveling nut limit switch is standard. It is a two position switch with adjustable upper and lower limits and is designed to prevent accidental hook over-travel.



An additional upper limit switch is standard as a backup and is designed to prevent hook over-travel in the "up" mode. It is activated by the bottom block.

Gear Trains



Gears and pinions in the Yale Cable King are machined from steel, and

then case hardened to reduce wear. Gear teeth are full depth, 20 degree straight spurs with modified involute form. The full depth and involute design reduce strain and wear by allowing greater surface area contact. Each component is tested for hardness, accuracy, form and fit to exacting tolerances. The entire gear train is enclosed in a rugged casing and lubricated in a continuous oil bath.

Motors



The Yale Cable King uses a heavy duty rotary piston air motor designed for high torque hoist duty. The motor provides excellent speed control for precision load spotting. It is lubricated by a continuous oil bath and incorporates an integral oil baffle, oil thrower, and large diameter crankcase breather plug. Normal operating air pressure is 90 psi. The four piston design provides for instant starting torque. Mufflers are standard.

Optional Equipment

There is a wide variety of Yale Cable King air hoist options to fit your application. Options include: Bullard hooks, speed couplers, hose trolleys, air hose, airline filters and oilers, flat tread wheels, and air motorized trolleys. See back page for spark resistant models.

Spark Resistant Cable King Air Wire Rope Hoist

The Yale Cable King air wire rope hoist easily adapts for use in many flammable environments because there is no danger of electrical sparking with an air motor. Mechanical accessories may be added to reduce the possibility of mechanical sparking. These accessories include bronze load hooks, stainless steel wire rope, and aluminum hand chain on geared trolley type.

chain on hand geared trolley models.

Note: In some cases, the use of stainless steel wire rope requires a larger diameter to maintain the same safety factor. This may in turn alter the lift. Consult the factor for specifics.



Caution Do not use Yale hoists or trolleys for passenger elevator applications.

There is a Yale hoist for every lifting job.

There is a Yale hoist to solve your toughest material handling problem. Select from:

- Hand hoists & trolleys to 50 tons;
- Ratchet lever hoists to 15 tons;
- Electric chain hoists to 3 tons;
- Air chain hoists to 6 tons;
- Air wire rope hoists to 35 tons;
- Electric wire rope hoists to 35 tons.

Yale variety lets you match your hoist to the job for maximum dollar value. Hoists in the Yale line are quality engineered and performance tested before they are shipped to you. That's why the Yale name has stood for quality for over 100 years. Look up to Yale for excellence in hoisting equipment.



Yale® Hoists

414 West Broadway Ave.
P.O. Box 769
Muskegon, MI 49443
866-805-2962
800-742-9270

Distributed By:

McLaughlin Hoist & Crane
1850 Larkin Williams Rd.
Fenton, MO 63026
(636)343-9700
Fax(636)343-0840

Yale®



HOIST
MANUFACTURERS
INSTITUTE
MEMBER COMPANY

